

## MULTI PROCESS CONTROL TRAINER



### Experimental capabilities

- Study of a pressure, level, flow and temperature regulation loop
- Identification of the elements: Sensors, Regulator, Actuator, Interference element
- Understanding of a PID control method
- Training in the use and configuration of control equipment
- Characteristic curve of a process: response time, evolution of the output signal of the regulator according to the setpoint
- Visualization of different signals in real time by software
- Discrete control (TOR)
- Wiring of control loops
- Data acquisition and controller control software provided.

## Operating principle

The MPR 100 trainer allows the study of multi-process regulation such as pressure, flow, level, temperature with configuration of parameters on PC.

A pump ensures the water supply in several circuits where the flow, temperature, level and pressure are regulated. Several types of sensors measure the corresponding parameters. A digital PID controller receives information on flow, pressure, temperature ... and must adjust the opening of the pneumatic control valve to reach the set point.

The unit is delivered complete, instrumented with technical and educational documentation in French as well as all the accessories necessary for proper operation (including supervision software).

The rugged design of this equipment makes it ideally suited for use in schools.

Its anodized aluminum structure on multidirectional wheels with brakes gives it great strength as well as great flexibility of integration into your premises. The manufacture of this equipment meets the European machine standards.

## Diagram

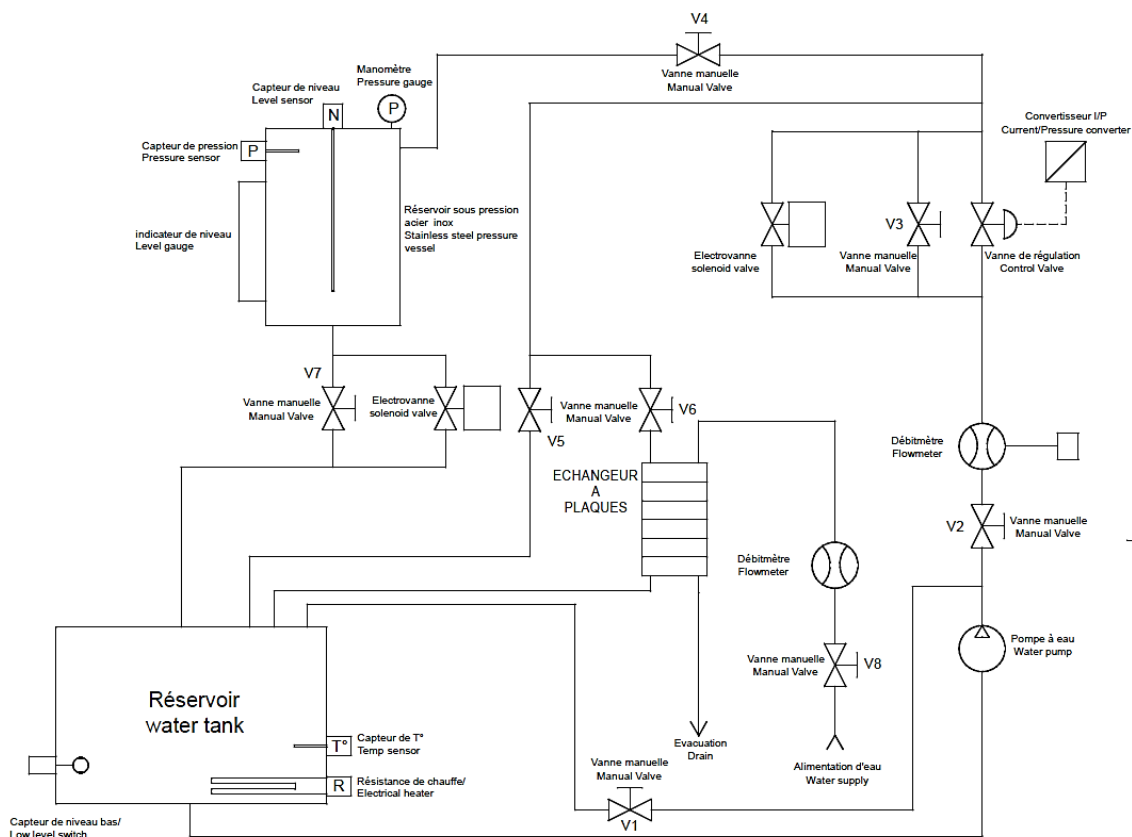

The unit includes: a water supply tank, an immersion heater, a centrifugal pump, an electrical box, a digital regulator allowing all the control loops to be created, actuators, a pneumatic valve, pressure sensor, level sensor, electronic flow sensor, float flowmeters, temperature probe, pressurized tank, plate heat exchanger. The bench allows the regulation of temperature, flow, pressure, level and temperature.

It is possible to use two different actuators (a pneumatic control valve with proportional I / P converter or a solenoid valve to achieve on-off control).

# MPR100



## Illustration

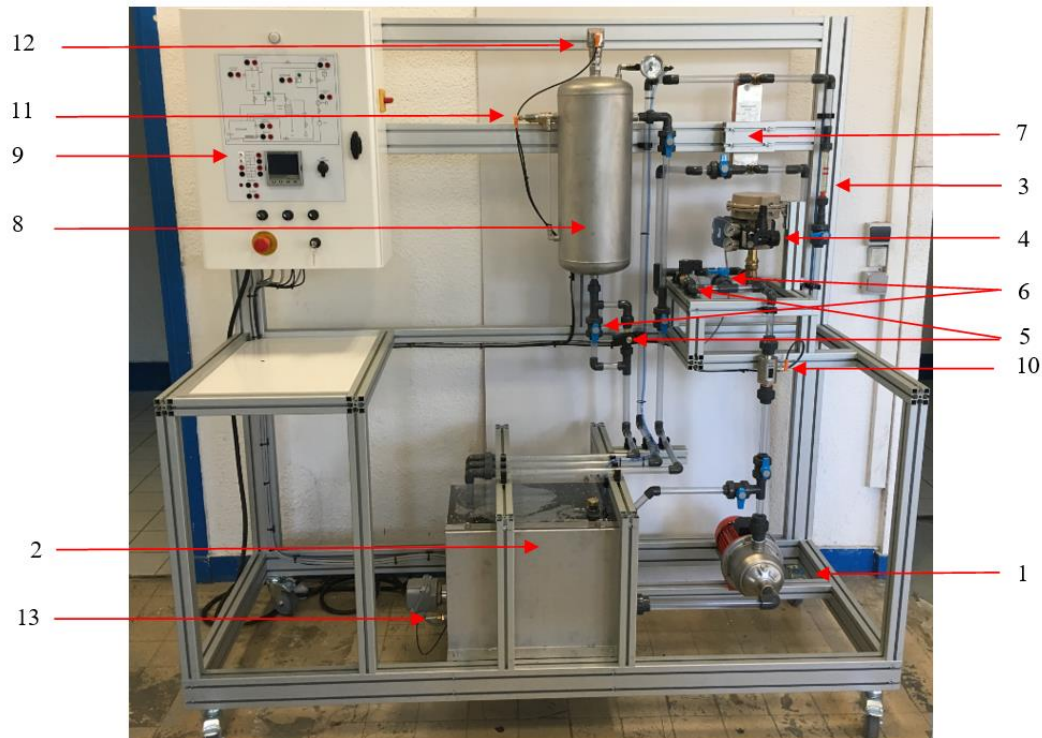

## Technical specifications

ITEM	DESIGNATION
1	Centrifugal pump $Q=5\text{m}^3/\text{h}$ et $H_m = 21\text{mCe}$
2	Stainless steel water tank $V=50\text{L}$ including : an immersion heater 6000 W ; low level switch and temperature switch to protect the heater
3	Float flowmeter 1.5-15 L/h
4	Control valve with positioner
5	ON/OFF solenoid valve for discrete control and perturbation
6	Manual valve for perturbation
7	Plate exchanger
8	Pressure vessel (stainless steel) $V=15\text{L}$ (level and pressure control) including : safety valve 3 bars pressure gauge 0-2,5 bars and level gauge
9	Synoptic with double well sockets to do the wiring of the regulation loop
10	Electromagnetic flowmeter 0-50 L/min
11	Pressure sensor 0-6 bars
12	Capacitive level sensor $L=700\text{mm}$
13	Temperature sensor (termocouple)

## Illustration

The first loop allows the study of flow regulation. It is composed of the water tank ( $V = 50L$ ), the pump N ° 1, an electromagnetic flowmeter and one of the actuators (pneumatic control valve or solenoid valve). The disturbance is effected by the ball valve located downstream of the actuator.

The second loop makes it possible to study the temperature regulation in the water tank ( $V = 50L$ ) with the immersion heater. It is made up of a water tank, the circulation pump N ° 1, the immersion heater, the plate heat exchanger, a temperature sensor (T) with analog output placed in the tank, a low level safety float and a safety system in the event of overheating. The disturbance is achieved by cooling with the aid of network water from the plate heat exchanger.

The flow sensor is on the cooling loop.

The third loop allows to study the regulation of pressure in the stainless-steel vessel ( $Vol = 15L$ ). It is composed of a water tank, of the pump N°1, of one of the two actuators, (regulating valve or solenoid valve), of the stainless-steel vessel and a pressure sensor with analogic output (P), a drain valve and a venting valve into the atmosphere. The disturbance is performed by a ball valve fitting which allows to create a leak of the stainless steel vessel towards the water tank.

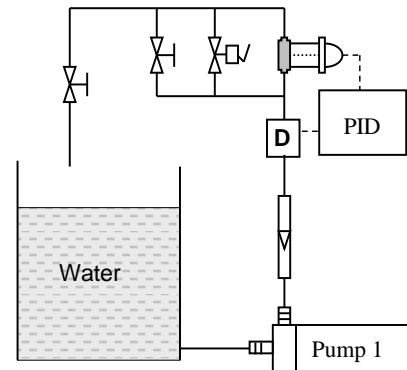

**Flow control**

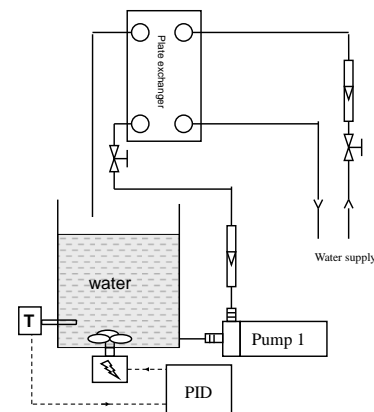

**Temperature control**

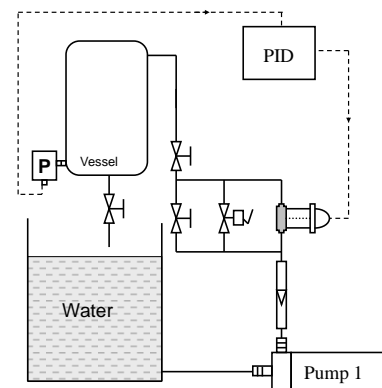

**Pressure control**

# MPR100



The fourth loop is used to study the regulation of the level in stainless steel vessel (Vol = 15L). It is composed of a water tank, of the pump N°1, one of the two actuators (regulating valve or solenoid valve) of the stainless-steel vessel and the level sensor (N) with analogic output. The disturbance is performed by a ball valve fitting which allows to create a leak from the stainless steel tub towards the water tank.

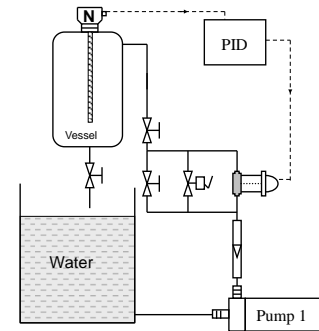

Level control

## Services required

## Documentation

- Electrical supply : 400 Vac – 50 Hz – 16 A
- Electrical network : 3 phase(s) + Neutral + Earth.
- Water supply : 15 L/min – 3 bars
- Compressed air supply: 3 bars (dry air)
- Water drain : on the floor
- Dimensions: (LxWxH mm): 1900 x 750 x 1940
- weight (Kg): 200

- User's manual
- Pedagogical manual
- Technical documentation of the components
- Lab exercises
- Wiring diagram
- Hydraulic diagram
- Data acquisition and control software
- Certificate of conformity CE

Note : if the equipment installation is operated by our staff, all supplies and exhaust connections required must stand at less than 2m from the machine

# MPR100



## Supervision : Parameterization, Plot of curves

The unit is also fitted as standard with a monitoring software and parameterization. The connection to the PC is realized via a standard USB port. The software is divided into two parts :

### PARAMETERIZATION :

This section provides access to the parameters display directly via a data browser similar to that of Windows.

The front panel of regulator is reproduced on the PC screen and the operator can actuate the buttons and controls as if he was on the pilot.

Parameterization of proportional gain, of integral gain and of derived gain.

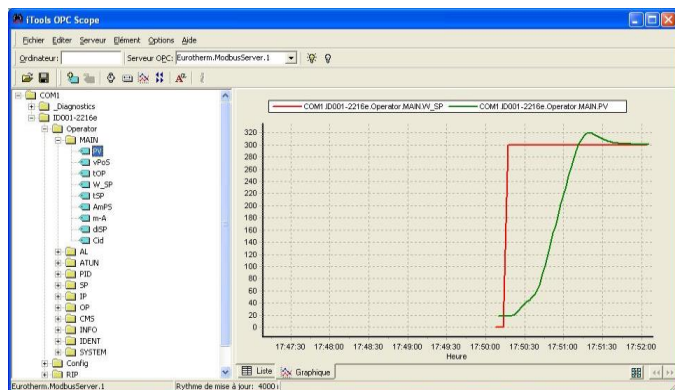
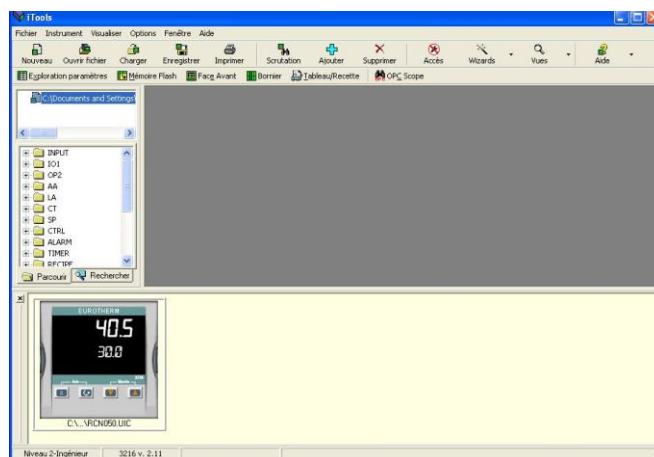

### PLOTTING OF CURVES:

This section allows you to draw the curves with the signals of the regulator. For example on this image below we visualize the setpoint and the real-time measurement, but it is possible to add other parameters such as the output signal....

The data stored during the plot can then be saved in a file in Excel format.