

## REFRIGERATION CYCLE DEMONSTRATION UNIT (AIR/WATER)

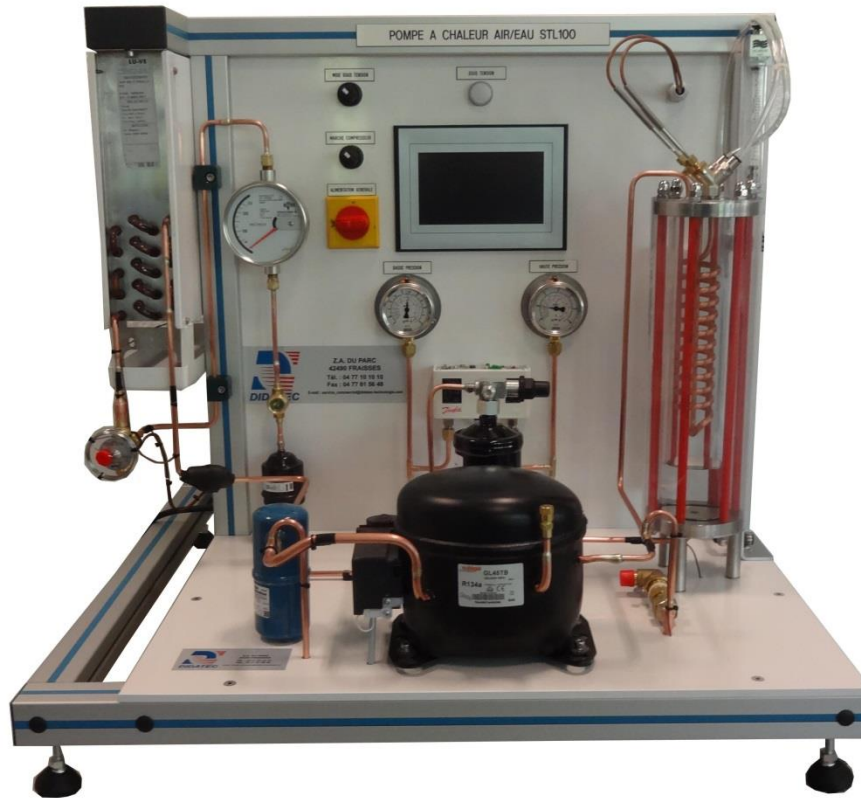

### Experimental capabilities

- Identification of circuit components of air / water heat pump
- Visualization of the condensation of the fluid in a glass exchanger
- Study of the thermodynamic heat pump cycle.
- Measure the yield of a refrigeration cycle
- Determination of the energy balances of the condenser, of the evaporator and the entire heat pump.
- Comparison of the vapor compression cycle established by manipulation with the ideal cycle on pressure-enthalpy diagram.

## Operating principle

The STL100 bench allows the study of refrigerating cycle.

The bench is made of standard elements of a refrigerating circuit. The compressor will first elevate the pressure and the gas temperature (R134a). The water condenser will then transform this high pressure gas into high pressure liquid. The students visualize the transformation because the refrigerant condenses between the glass shell and the cooling coil

The high pressure liquid will then be stored in a bottle and then be sent towards the expansion valve. This one will change the state of the fluid, it will go from a high pressure liquid to a low pressure liquid. This low pressure liquid is now in the evaporator and will draw its energy on the air (and thus cooling it). At the outlet of the evaporator, the fluid is in the form of low pressure steam, it goes through a suction line accumulator and will be compressed once again by the compressor.

The robust design of this device makes it suitable for use in schools.

The equipment is set up on an Anodized aluminium frame on casters wheels. This gives it great strength and a flexibility of integration into your premises.

The manufacture of this equipment complies with the European standard for machinery manufacturing.

This equipment can be used alone or with other compatible equipment from our range (see last section of this document).

## Illustrations

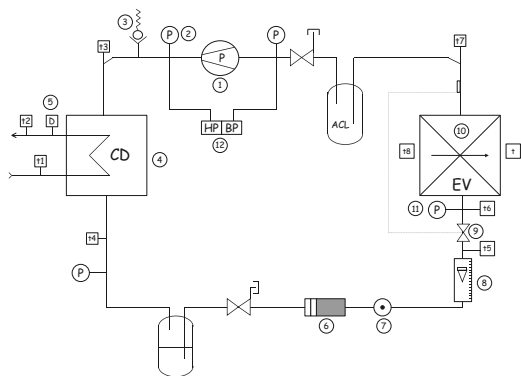

This unit is set up on a frame made of aluminum profile with 4 feet. It includes an electrical cabinet with main switch and differential circuit breaker.

1. Hermetic piston compressor 408W for a plan 7.2 °C / 55 °C Electrical power: 1/8 CV
2. High pressure manometer R134a with dual scale temperature / pressure
3. High pressure safety valve
4. Condenser water / R134a
  - Resistant shell glass (pressure and temperature)
  - Copper coil
  - Volume of the exchanger: 1.19L
  - Fluid circulation between the grille and the coil
  - Rear lighting by neon (improves the visualization)
5. Water float flowmeter

## Technical details

6. Dehydrator
7. Indicator of fluid state
8. R134a refrigerant flowmeter with needle with magnetic transmission
9. Thermostatic expansion valve with internal pressure equalization
10. Air evaporator, forced convection, copper tube and aluminum fins
11. Low pressure manometer R134a with dual scale temperature / pressure
12. Safety pressure switch HP / LP

Integrated instrumentation:

- Low pressure manometer: -1 to 10bars
- High pressure manometer: -1 to 30bars
- Fluid flowmeter R134a: 40 to 250mL /min
- Water flowmeter : 0.2 1.5 L/min
- Thermocouple temperature probes T (X9): -20 to +100°C
- Compressor power wattmeter: 0 to 1150W

The temperatures and the power are displayed on a 7" touch screen :

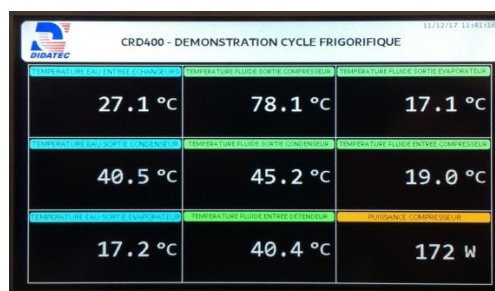

## Services required

- Electrical supply : 230 Vac – 50 Hz – 10 A
- Water supply : 1.5 L/min – 25 ° maxi
- Dimensions: (LxWxH mm): 880 x 600 x 660
- weight (Kg): 50

Note : if the equipment installation is operated by our staff, all supplies and exhaust connections required must stand at less than 2m from the machine

## Documentation

- User's manual
- Pedagogical manual
- Technical documentation of the components
- Lab exercises
- Wiring diagram
- Fluidic diagram
- Enthalpic diagram
- Certificate of conformity CE

DIDATEC– Zone d'activité du parc – 42490 FRAISSES- FRANCE  
 Tél. +33(0)4.77.10.10.10 – Fax+33(0)4.77.61.56.49 – [www.didatec-technologie.com](http://www.didatec-technologie.com)  
 email : [service\\_commercial@didatec-technologie.com](mailto:service_commercial@didatec-technologie.com)

Reproduction interdite / copy prohibited– Copyright DIDATEC juin-23- page 2

Dans le cadre de l'amélioration permanente de nos produits, ce descriptif technique est susceptible d'être modifié sans préavis

As part of the continuous improvement of our products, this technical specification may be modified without previous notifying

## Options

- Utility module
- Data acquisition system and real time drawing of the enthalpic diagram  
3 temperature sensors and 2 pressure sensors (HP and LP)
- Full Data acquisition system and real time drawing of the enthalpic diagram  
temperature sensors, 2 pressure sensors (HP and LP), 2 flow sensors (water and frigorific fluid)
- Ref : STL050
- Ref : STL101
- Ref : STL102

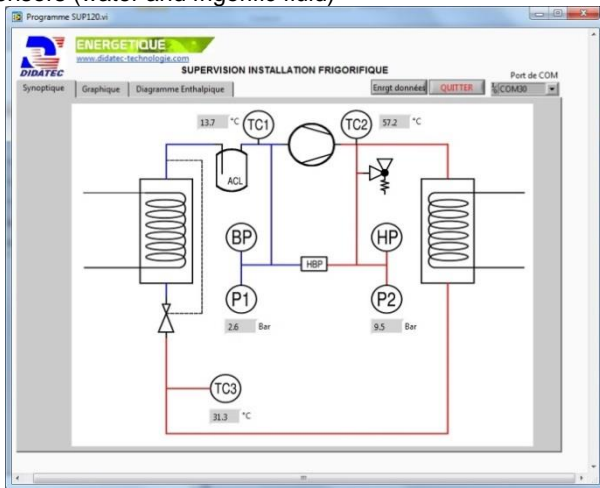

Schematic diagram with real time display

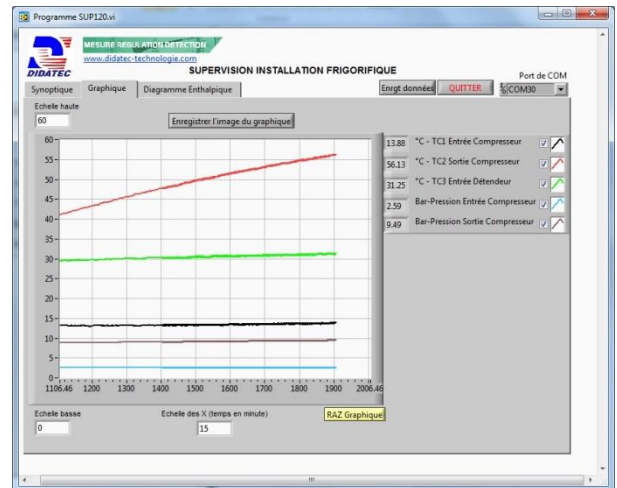

Real time trend

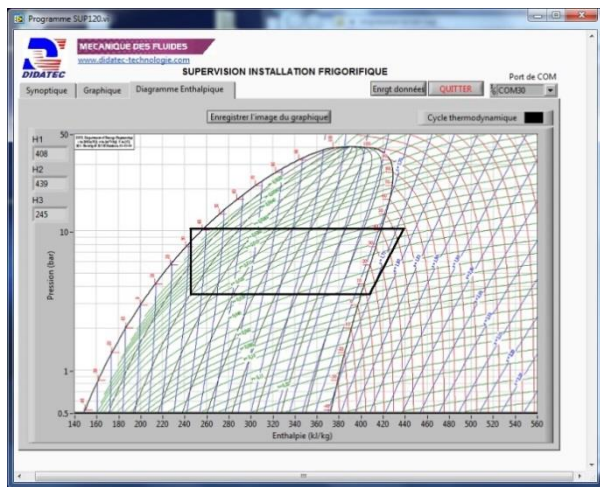

Real time enthalpic diagram