

AGITED TANK 75L



Experimental capabilities

- Additional material of another process

Operating principle

The bench GPACU0 can be used as a storage tank to the output of any process.

The robust design of this equipment makes it perfectly suited for school use.

Its anodized aluminum structure on wheels makes it very robust as well as great flexibility of integration into your premises.

The manufacture of this equipment meets the European machine directive.

Illustrations

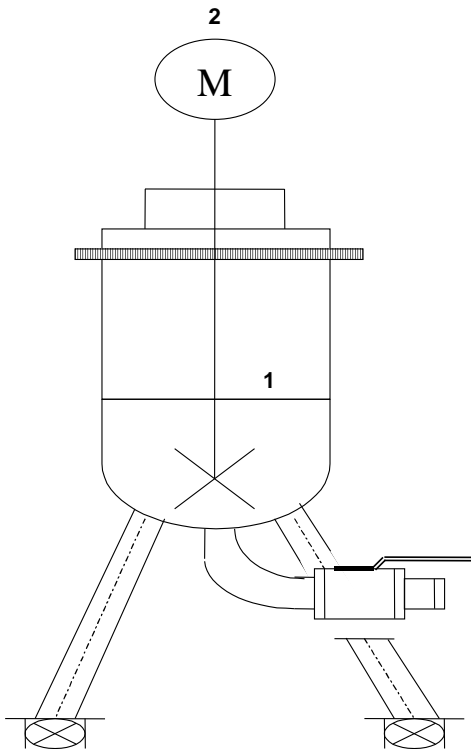

Technical details

1. Storage tank
- Volume: 75 L
 - Material: stainless steel
 - Drain Valve

2. Agitator
- Power: 0.55 kilowatts
 - Stirring speed: 0-600 rev/min
 - Pale and stirring shaft 316L stainless steel
 - With manual control speed variator

Services required

- Electrical supply: 380 Vac - 50 Hz - 20 A
- Electrical supply type: 3 Phase + Neutral + Earth
- Dimensions: (LxWxH mm): 600 x 900 x 1650
- weight (Kg): 90

Documentation

- User's manual
- Technical documentation of the components
- Certificate of conformity CE

Note : if the equipment installation is operated by our staff, all supplies and exhaust connections required must stand at less than 2m from the machine